

# Operating and mounting instructions

## PowerBlock o16

Order number: 77024-180-02

### General usage

Power Block series consists of 4 different devices types. It can be installed in a standard distribution board.

- 4 DIN Rail module for 4 outputs and 6 inputs
- 4 DIN Rail module for 8 outputs
- 4 DIN Rail module for 8 inputs 230 VAC
- 4 DIN Rail module for 4 Blinds/Shuter 24 VDC
- 8 DIN Rail module for 8 outputs and 8 inputs
- 8 DIN Rail module for 16 outputs



Overview of the functionalities:

Outputs	
BINARY ( POWER LEDs SUPPORTED)	SHUTTER / BLIND
Bus failure Central ON/OFF Counters Scenes Timers Alarms Disable function Manual control	Bus failure Scenes Presets Alarms Disable function Manual control

ADVANCED FUNCTIONS	
Analog & digital alarms Scene controller Timers (with cyclic sending of time remaining) Overwrite end user parameters	Logic functions Advanced scene controller Setpoints Behavior at bus recovery DPTs obj

### Device type and accessories

At present the following device types are available in the PowerBlock control group:

Product	Description	Order number:
PowerBlock o8	8 capacitive outputs	77024-180-01
PowerBlock o8m	8 capacitive outputs	77024-180-04
PowerBlock o16	16 capacitive outputs	77024-180-02
PowerBlock o16m	16 capacitive outputs	77024-180-05
PowerBlock io64	4 capacitive outputs + 6 analog/digital inputs	77024-180-03
PowerBlock io88	8 capacitive outputs + 8 analog/digital inputs	77024-180-07
PowerBlock s4 DC	4 Jalousie Ausgänge 24VDC	77024-180-11
InBlock i8 HV	8 x 230VAC inputs	77024-180-30

### Scope of delivery

The following individual components are included in the delivery of the PowerBlock device:

- KNX Actuator
- KNX bus connector
- KNX protection cap
- Operating and mounting instructions

### Application programs

The following application program is currently available for the PowerBlock device:

- 77024-PowerBlock o16-12-0112 – Version 1.2

### Installation device



Risk of death by electric shock.

- The device is intended for interior installation in dry rooms.
- The device must only be installed and commissioned by an accredited electrical engineer.
- When planning and installing systems, the guidelines, rules and regulations, as well as the valid KNX guidelines of the respective country must be observed.
- For the installation the device must be switched to zero potential.
- The device must not be opened.
- Any faulty devices are to be sent together with a return delivery to the manufacturer.

### Technical data

POWER AND OUTPUTS SPECIFICATIONS		
<b>Power supply</b>	Supply Voltage:	21..30VDC
	Max. Consumption: Additional power supply:	9,4mA No
<b>Number of outputs</b>	Contacts:	16 Dry contact (potential-free)
<b>Output configuration</b>		Up to 16 outputs Up to 8 channels
<b>Maximum switching capacity per output</b>	AC rated current / voltage:	16A / 230VAC 50/60Hz
	Capacity Load: DC rated current / voltage:	max. = 140µF 16A / 30VAC
<b>Maximum inrush current per output</b>	max. 200µs:	800A
	max. 20ms:	165A
<b>Maximum load per output</b>	Resistive:	2500W
	Incandescent lamps:	2000W
	Halogen lamps 230V: Fluorescent lamps uncorrected / not compensated:	2000W 1000W
	LED lamps: Motor power:	400W 1380W
<b>Max. total current of the actuator</b>		120A
<b>Phases switching distribution</b>		1 independent phase allowed per connector side, one above and one below
<b>Output life expectancy</b>	Mechanical:	> 1x10 <sup>6</sup> operations (at 60 times/min)
	Electrical:	> 4x10 <sup>4</sup> cycles with resistive load at maximum current
<b>Connections</b>	KNX bus connector:	0,8 mm Ø solid
	Terminal screw block:	Max. 6 mm Ø solid
	Tightening torque for terminal screw:	Maximum 0.6 Nm

GENERAL SPECIFICATIONS		
<b>Control and display elements</b>	Programming button:  LED, red: 16 x buttons: (for manual channels control) 16 x LEDs, red:	To assign the physical address. To switch On/Off outputs / Move Up/Down channels To display actual outputs/channels status
<b>Mechanical data</b>	REG casing 8TE: Width: Height: Length: Weight Mounting:	Plastic ABS – V0 140 mm 58 mm 90 mm 235 g 35 mm DIN rail
<b>Electrical safety</b>	Pollution class: Protection type:* Protection class:** Overvoltage category: KNX Bus:	2 IP20 III III SELV DC 30V
<b>EMC requirements</b>	Complies with:	EMC directive 2014/30/EU
<b>Environmental conditions</b>	Weather resistance: Environmental conditions in operation: Storage temperature: Transportation temperature: Rel. humidity: (non condensing)	EN 50090-2-2  -5°C to +45°C -25°C to +55°C  -25°C to +70°C 5 % to 93 %
<b>Certification CE-Signage</b>	KNX registered: According to EMC-Guidelines:	Yes (Residential and commercial buildings), Low Voltage guidelines

\* (according to EN 60529); \*\* (according to IEC 1140)

#### Location and function of the LEDs and control elements

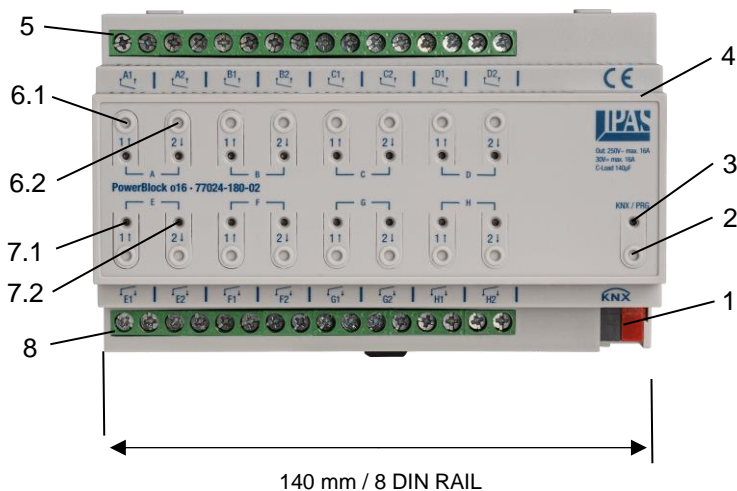

- 1: KNX bus connector
- 2: Programming button
- 3: Programming LED
- 4: SD card slot (only for internal use)
- 5: Outputs connector: Channel A, B, C, D

#### 6.1: Manual control (See Annex 1)

Blind channel:  
- Long press: Move Up (LED blinks while moving)  
- Short press: Stop/Step  
Binary channel:  
- Short press: Output toggles to ON/OFF

#### 6.2: Manual control (See Annex 1)

Blind channel:  
- Long press: Move Down (LED blinks while moving)  
- Short press: Stop/Step  
Binary channel:  
- Short press: Output toggles to ON/OFF

#### 7.1: LED output/channel status

Binary channel LED ON = Output ON, LED OFF = Output OFF /  
Shutter: LED blinks while moving UP

#### 7.2: LED output/channel status

Binary channel LED ON = Output ON, LED OFF = Output OFF /  
Shutter: LED blinks while moving DOWN

- 8: Outputs connector: Channel E, F, G, H

#### Mounting and wiring

As an REG device, the Power Block series are suitable for mounting in distribution boxes on 35 mm DIN rails and wall boxes.

To mount the device, it must be angled to slide onto the DIN rail from above and then locked into place with a downward movement.

Please make sure that the security latch at the bottom side of the device snaps into place and that the device is firmly attached to the rail. To dismount the device, the security latch can be pulled downwards with a suitable tool and then the device can be removed from the rail.

After the device has been inserted, the cables for the Outputs should be attached to the upper and lower connectors .

To connect the KNX cable, a standard KNX bus terminal and a protection cap are included with the device.

Please make sure that the KNX cable is installed with the protection cap as shown in the drawing below.

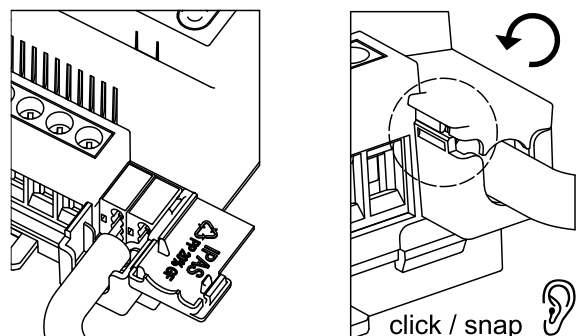
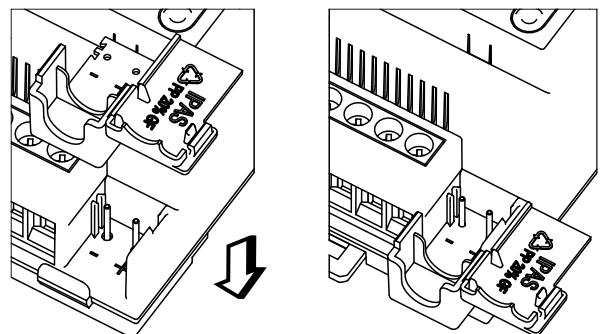

## OUTPUT SCHEMATIC

Each channel can be configured to be used as 2 binary outputs or as one blind channel. **Each connecting side (above and below) can be powered by an independent phase.** The example circuit diagram uses 1 phase for the output channels A, B, C and D and 1 phase for channels E, F, G and H.

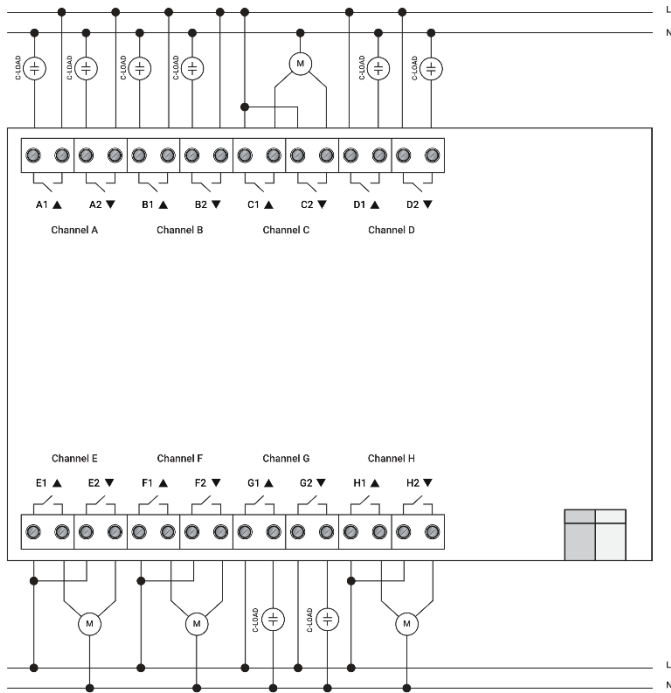

### ANNEX 1: Manual Control

The Power Block actuator has 2 push buttons and 2 status LEDs for each channel on the front side. These buttons can be activated to control each and every channel/output individually if you select "yes" in the relevant parameter options in Binary outputs and/or Shutter/Blinds. The LEDs are arranged in two rows, whereas the LEDs represent:

#### For Binary outputs



- The top row: channels A1, A2, B1, B2, C1, C2, D1, D2
- The bottom row: channels E1, E2, F1, F2, G1, G2, H1, H2

#### For Shutter/blinds:

- The top row: A1 -> UP, A2 -> DOWN, B1 -> UP, etc.
- The bottom row: E1 -> UP, E2 -> DOWN, F1 -> UP, etc.

## MANUAL CONTROL – PARAMETER

The Parameter Mode allows you to control all the channels of the actuator as configured in the ETS. The Action simulates a telegram received at the switching object of the selected channel.

BINARY	SHUTTER/BLIND
<p><b>Press action:</b> Sends Toggle ON/OFF command "0/1" to the "Switching" object.</p> <p> LED = ON (indicates channel status)</p> <p> LED = OFF (indicates channel status)</p>	<p><b>Long press action (Channel output 1):</b> Sends a UP command "0" to the "Move" object.</p> <p><b>Long press action (Channel output 2):</b> Sends a DOWN command "1" to the "Move" object.</p> <p><b>Short press action (any output) (while shutter/blind is moving) of same button:</b> Sends a Stop... command to the "Stop..." object.</p> <p> LED blinks while moving UP/DOWN during parameterized time.</p>

## MANUAL CONTROL – TEST

The Test Mode allows you to test all the loads/wiring connected to the channels. It is independent from the ETS configuration of the actuator (since the "Manual Control / Param mode + Test mode" is a default option, you can use the Test mode even before programming the actuator).

**Important note:** Should a blind/shutter be connected to a channel, the 2 channels may never be closed at the same time. Therefore, even in Test mode, if the channel is configured as a blind, this safety measure is implemented. For this reason, it is better to first commission the OUTPUT: CHANNEL TYPE SELECTION before using the Test mode.





To change into the test mode, any button can be used depending of the channel configuration:

- If "Binary" channel is configured: Press any button for at least 500ms
- If "Blind" channel is configured: Press the two buttons of any channel at the same time for at least 500ms

To change back to the normal "Parameter Mode" the same procedure should be repeated. Be aware by changing back to "Parameter Mode" the device will restart. Also after the device has restarted and if the channel is configured to be a blind channel, it will do a calibration movement on the first movement command.

 In order to indicate that the actuator is in Manual Control / Test Mode, the LED of the selected channel is continuously making a short blinking action every second; no matter whether the channel is ON (LED ON) or OFF (LED OFF).

The Action switches/moves the channel, as you can see in the table below:

BINARY	JALOUSIEN/BLENDE
<p><b>Press action:</b> Sends toggle ON/OFF command to the relay (ON = Contact closed / OFF = Contact open)</p> <p> LED = ON (indicates channel status)</p> <p> LED = OFF (indicates channel status)</p>	<p><b>Rising edge press action (Channel X):</b> Contact closed</p> <p><b>Falling edge press action (Channel X):</b> Contact open</p> <p> LED = ON (indicates channel status)</p> <p> LED = OFF (indicates channel status)</p>